

A Brief Overview of Power and Current in Polyphase Power Systems

By Jeff Newmiller (jdnewmil@dcn.davis.ca.us)

12/16/2005

This document arose from a question posed by an electrician reading about ac power in an old reference book: “why would anyone have ever tried to use two-phase power at 90 degrees out of phase? What about the other 270 degrees? Wouldn’t the power come in two pulses with a dead time before more power was delivered?” Thus, the focus here is on what ac power curves look like. There are plenty of complexities associated with measuring or connecting polyphase power that are omitted here for brevity.¹

Figure 1 shows the power changing as the ac voltage across a resistor rises and falls with time for two cycles, though time is shown in degrees of rotation because it applies equally to 60Hz and 50Hz (this would be about 33ms on an oscilloscope trace for 60Hz waves). The power curve is found by squaring the voltage and dividing by the resistance at each point along the voltage sine wave. The power reaches a maximum when the voltage is either maximum or minimum, and the power reaches zero when the voltage is zero (changes sign). Note that the power curve is a sine wave² which is offset upward... it doesn’t change signs like the voltage does.³ The average value is halfway between the peaks, or a little more than one kilowatt in this example.⁴

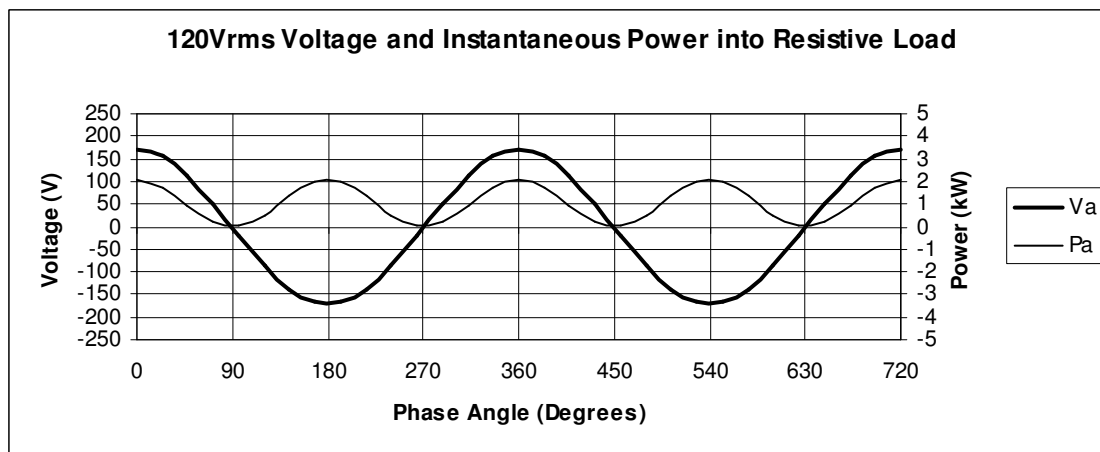

Figure 1. Voltage and Power Waveforms

¹ Hint: Phasor diagrams are used frequently in polyphase power analysis to reduce the complexity of thinking about sine waves to a minimum.

² The frequency of the power sine wave is twice the frequency of the voltage sine wave.

³ Reactance causes the power to change signs briefly... the negative power cancels out some of the useful positive power. This cancelled power is the reactive power we refer to with inductive or capacitive loads.

⁴ This also illustrates the difference between “rms” voltage, and “average power”. “RMS” is “root-mean-square”, a mathematical trick for finding a single positive number to represent the positive and negative swings of voltage or current that works like a dc voltage or current in Ohm’s Law and power calculations. It doesn’t make sense to do the RMS calculations for power, because it doesn’t have any useful meaning. The correct usage is to multiply “rms voltage” and “rms current” to get “average power”, assum.

The idea that the power reaches a maximum both when the voltage is positive and negative bears repeating... do not fall into the trap of thinking that power is only delivered when the voltage is at its maximum. Neglecting the inductive characteristic of single-phase ac motors for a moment (as should be reasonable under very low load), the torque on the motor will pulse twice every cycle, or 120 times per second for 60Hz voltage.

Split Phase

Figure 2 shows the basic split-phase connection diagram commonly used throughout the United States for residential power. Figure 3 shows the curves we get when we watch the voltage changing with voltage meters (oscilloscopes) "Va" and "Vb". Note how the meters are arranged... the negative lead is connected to the neutral for both meters. When you look at the waves in Figure 3, any time Va is positive, Vb will be negative. However, if you hook one meter instead of two, with the negative lead connected to the "B" phase and the positive lead connected to the "A" phase, this looks like $120 - (-120) = 240$ Vrms.

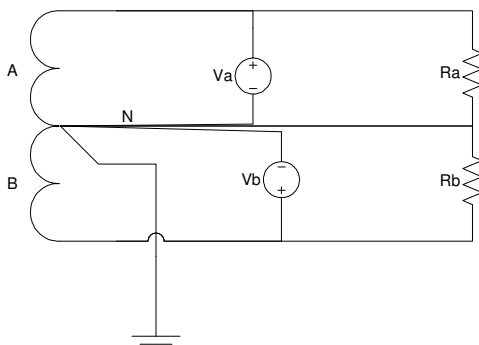

Figure 2. Split-Phase Diagram

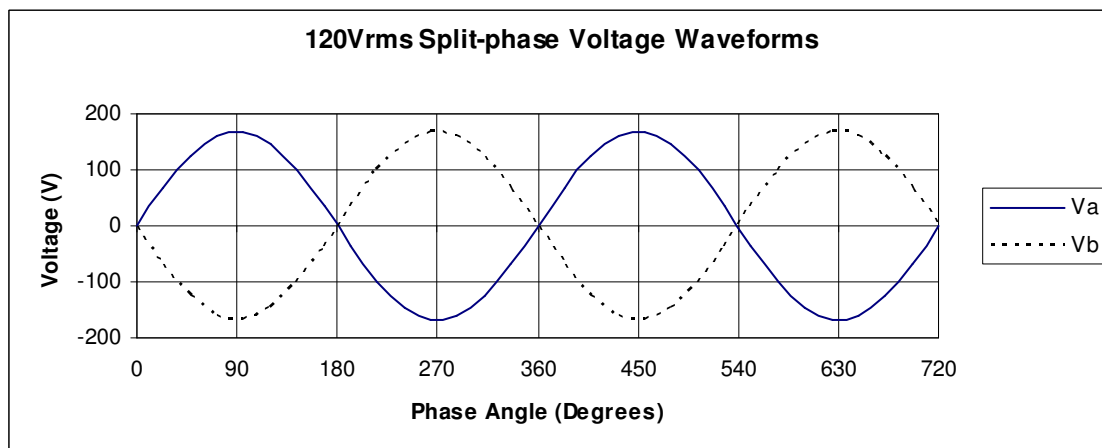

Figure 3. Split-phase Voltage Waveforms

Reviewing Figure 3 and keeping in mind that power reaches a maximum whether the voltage is positive or negative, it should make sense that the total power delivered by a split-phase connection is just double that of a single phase as seen in Figure 4.

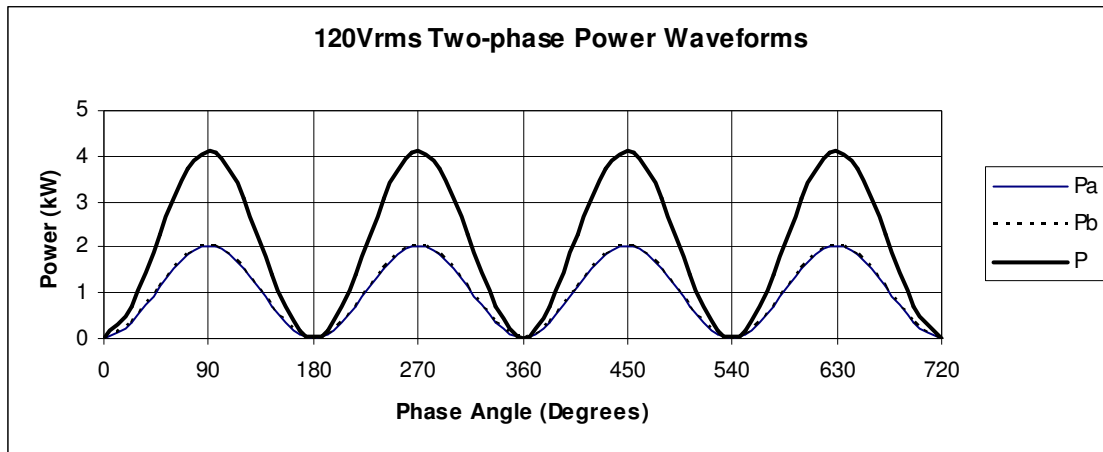

Figure 4. Split Phase Power Waveforms

Split phase current waveforms are 180 degrees out of phase with each other, so when the loads are balanced the neutral current cancel out as shown in Figure 5.

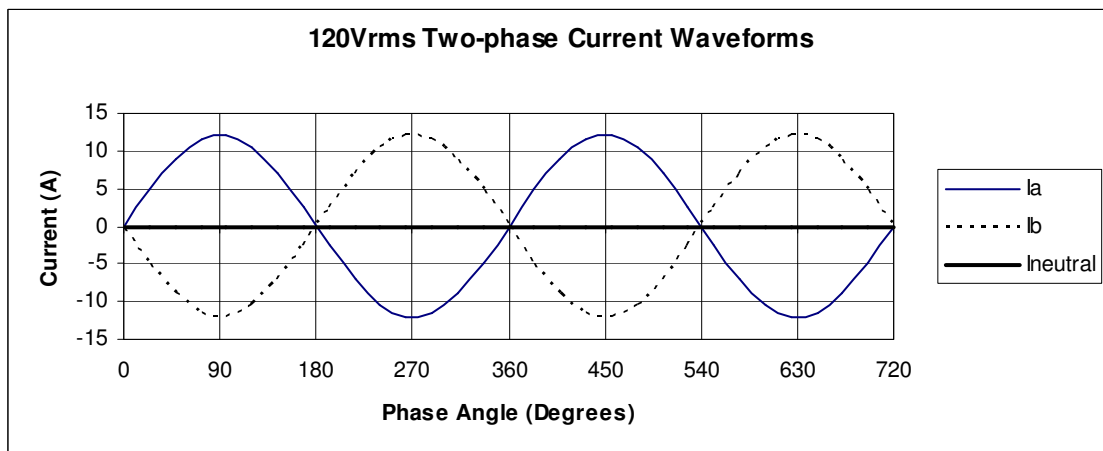

Figure 5. Split-Phase Current Waveforms

End Connected Two Phase

End connected two phase power systems are obsolete, but understanding their principles of operation can make understanding three phase power systems easier. Figure 6 shows the basic connection diagram, and Figure 7 shows the voltage waveform. Like the split phase system, power is delivered through three wires, but the waveform phasing is different.

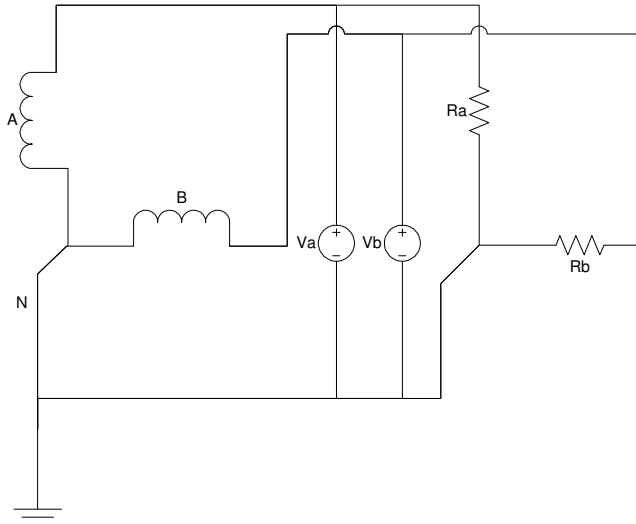

Figure 6. End Connected Two-Phase Diagram

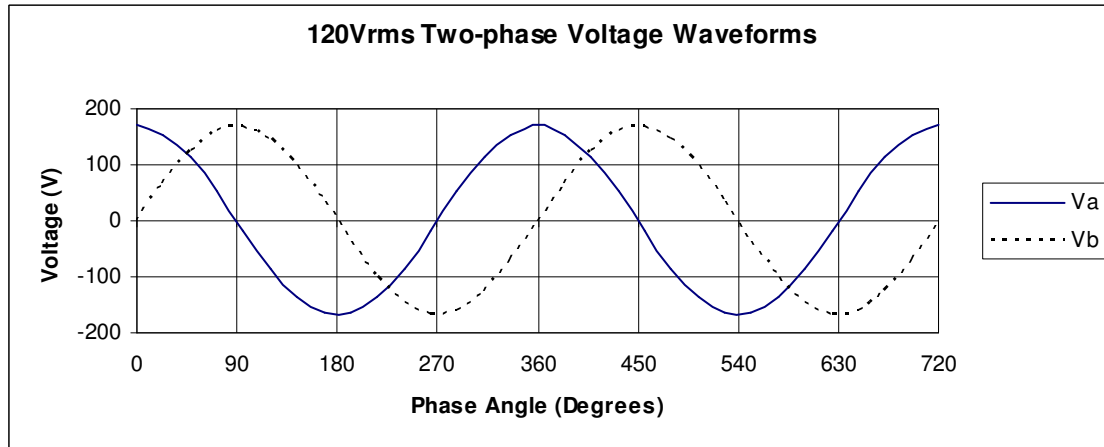

Figure 7. End Connected Voltage Waveforms

Figure 8 shows the power waveforms from both phases. You can confirm this by reviewing Figure 7 to see that the waveforms are shifted by 90 degrees, and then shifting the power wave from Figure 1 to the right by 90 degrees. Because there are more peaks in the power wave than the voltage wave, this 90 degree shift is enough that the power waves look completely out of phase. The big advantage to the two-phase system becomes apparent when you add these two waves together to get the total power delivered by the two phase system... each phase picks up the slack of the other at all times, and the total power doesn't vary at all! If the load were a motor, there would be no pulsing torque in the shaft as it turned.

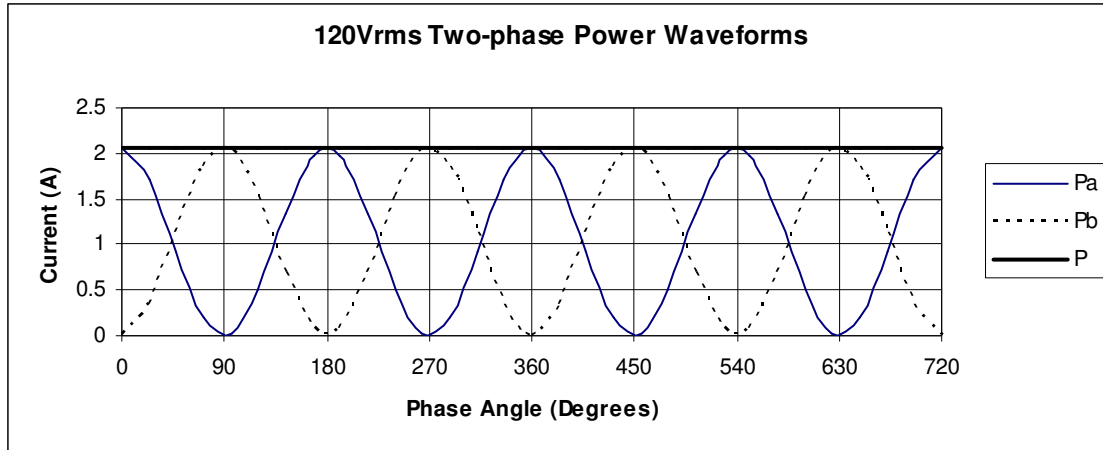

Figure 8. Two-Phase Power Waveforms

Figure 9 shows the drawback of connecting the two phases in a three-wire configuration... namely, the current in the neutral leg is always larger than the currents in the phase wires, so that conductor must be larger than the phase conductors have to be.

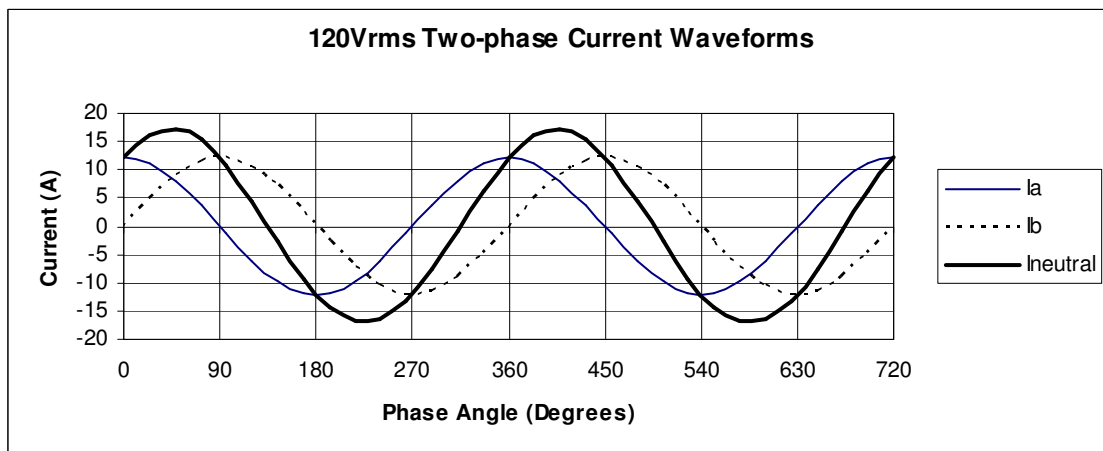

Figure 9. End Connected Two-Phase Current Waveforms

Center Connected Two-Phase

Figure 10 shows a center connected two-phase power configuration. Phases A and C are really one center-tapped transformer coil, as are B and D. Plots will be omitted in this case, because there are so many waveforms the plots would no longer clearly convey information. The phase pairs A-C and B-D behave like split phase power, while adjacent pairs A-B, B-C, C-D, and D-A behave like end-connected two-phase power. Overall, this arrangement has the constant power delivery advantage of end-connected two-phase power with the neutral current cancellation advantages of split-phase, but five wires are required.

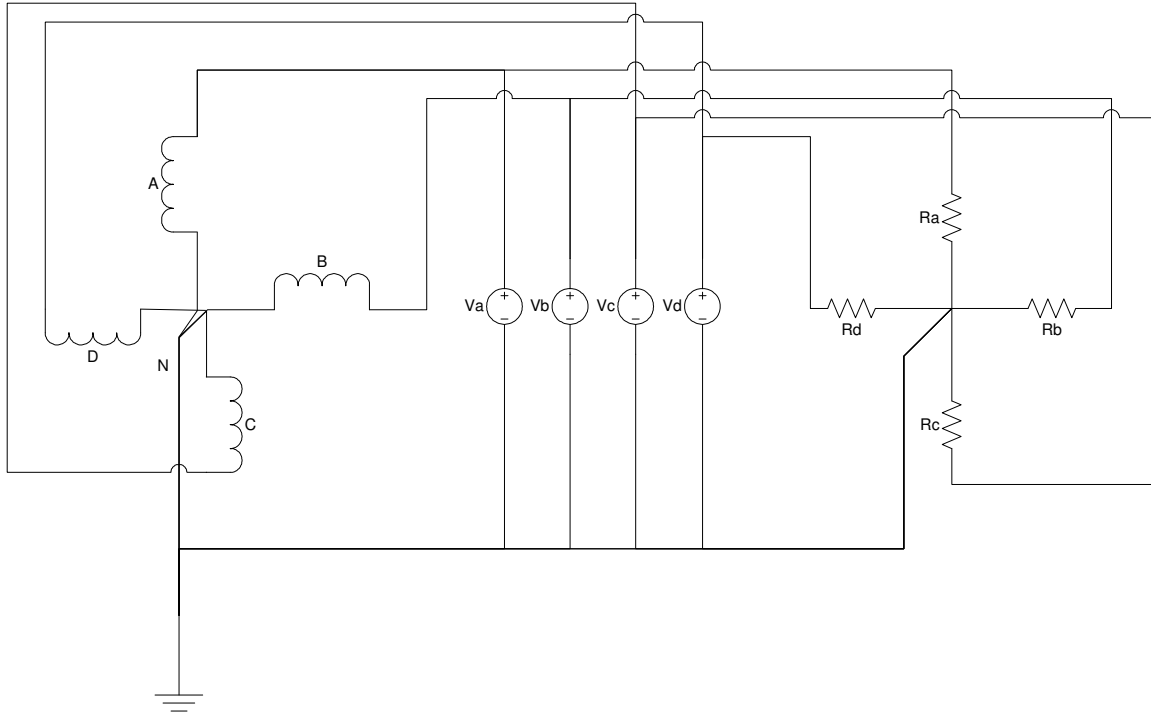

Figure 10. Center Connected Two Phase Diagram

Three-Phase Four-Wire Wye

In a standard three-phase four-wire wye-connected power system (as in Figure 10 but with one fewer phase), the voltage waveforms are shifted by 120 degrees as in Figure 11.

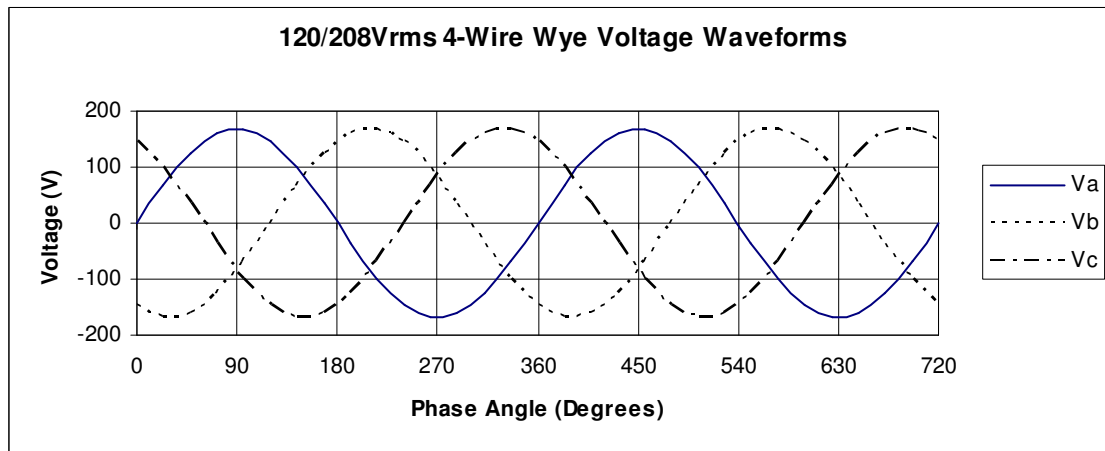

Figure 11. Three-Phase Four-Wire Wye Voltage Waveforms

Figure 12 shows the power waveforms for this configuration. As with the two-phase power system, total power is not delivered in pulses at all because of the way the waveforms take up each other's slack.

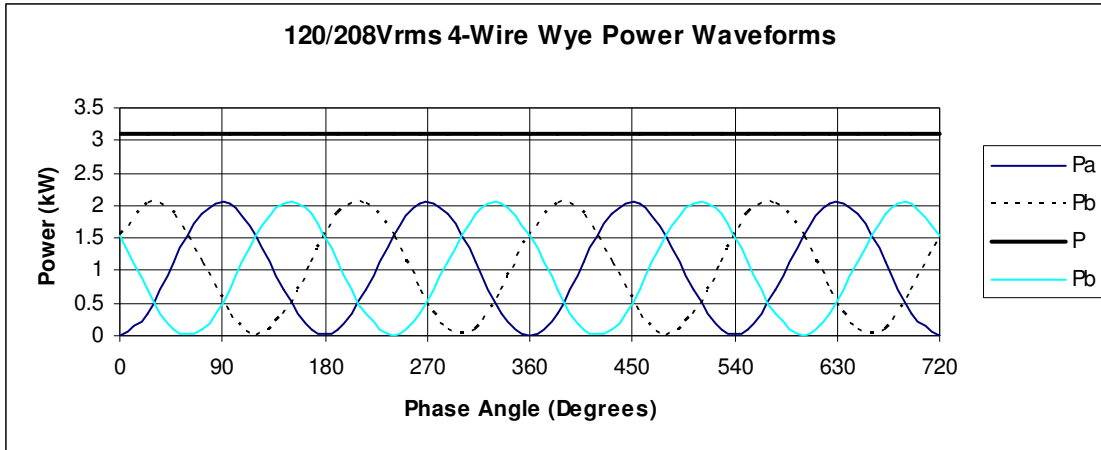

Figure 12. Three-Phase Four-Wire Wye Power Waveforms

Figure 13 shows that the neutral current cancels out in a balanced three-phase four-wire wye system.

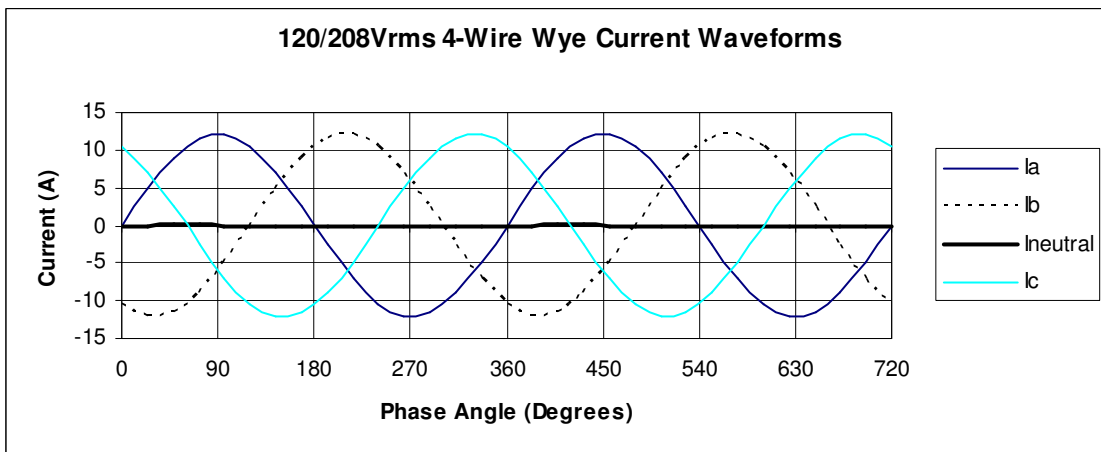

Figure 13. Three-Phase Four-Wire Wye Current Waveforms

A three-phase power system has the same benefits as the center-connected two-phase power system, using one fewer conductor. It would be hard to imagine any electrical engineer specifying installation of a new two-phase power system today because the efficient use of conductor material advantage of split-phase and three-phase are taken for granted now.